

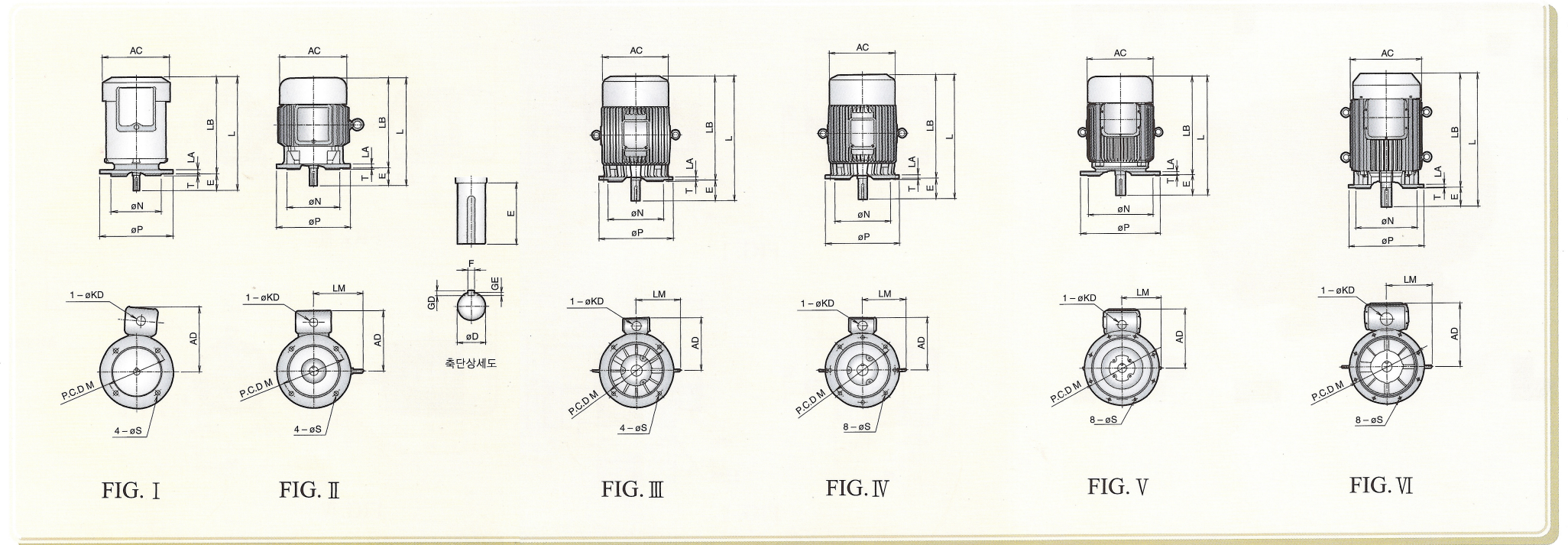

전폐플랜지형 전동기

0.4~200kW

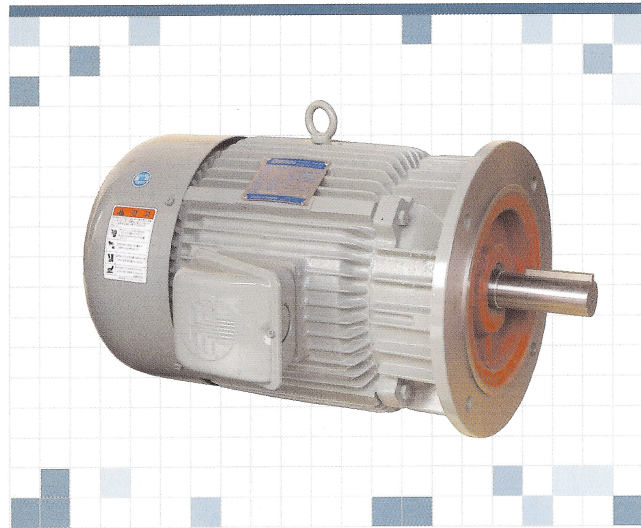

Fr. No.	FIG.	출력(kW)				AC	AD	L	LB	M	ØN	ØP
		2P	4P	6P	8P							
71M	I	0.4	0.4	—	—	148	150	245	215	130	110	160
80M	II	0.75	0.75	0.4	—	180	158	299	259	165	130	200
90L	II	1.5, 2.2	1.5	0.75	0.4	199	172	365	315	165	130	200
100L	II	—	2.2	1.5	0.75	222	180	406	346	215	180	250
112M	II	3.7	3.7	2.2	1.5	244	205	390	330	215	180	250
132S	II	5.5, 7.5	5.5	3.7	2.2	284	220	459	379	265	230	300
132M	II	—	7.5	5.5	3.7	—	—	497	417	—	—	—
160M	III	11, 15	11	7.5	5.5	337	272	584	474	300	250	350
160L	III	18.5	15	11	7.5	—	—	628	518	—	—	—
180M	III	22	—	—	—	374	282	668	558	350	300	400
		—	18.5, 22	—	—			647	537			
		—	—	15	11			668	558			
180L	III	30	—	—	—	374	288	706	596	350	300	400
200L	IV	37, 45	—	—	—	414	409	761	651	400	350	450
		—	37, 45	30, 37	18.5, 22			791				
225S	V	55	—	—	—	456	434	787	677	500	450	550
250S	VI	75	—	—	—	507	495	817	796	500	450	550
		—	75	55	37			906				
250M	VI	90	—	—	—	507	495	936	834	500	450	550
		—	90	75	45			944				
280S	VI	110	—	—	—	574	491	974	885	600	550	660
		—	110	90	55			995				
280M	VI	132	—	—	—	574	491	1055	936	600	550	660
		—	132	110	75			1046				
280L	VI	160, (150)	—	—	—	574	491	1106	1087	600	550	660
		200, (185)	—	—	—			1197				
		—	160, (150)	132	90			1257				
—	—	200, (185)	160, (150)	110	—	—	—	—	—	—	—	—

LA	T	ØS	ØKD	LM	베어링번호			축단치수			중량 (kgf)				
					부하측	반부하측	*ØD	E	F	GD		GE			
9	3	10	22	—	6203ZZ	6202ZZ	14 j6	30	5	5	3	11			
10	3.5	12	22	—	6204ZZ	6203ZZ	19 j6	40	6	6	3.5	30			
12	3.5	12	22	—	6205ZZ	6204ZZ	24 j6	50	8	7	4	32			
13	4	15	28	145	6206ZZ	6205ZZ	28 j6	60	8	7	4	48			
13	4	15	28	165	6207ZZ	6205ZZ	28 j6	60	8	7	4	52			
16	4	15	28	185	6209ZZ	6206ZZ	38 k6	80	10	8	5	80			
												87			
16	5	19	45	221	6309ZZ	6207ZZ	42 k6	110	12	8	5	138			
												146			
20	5	19	45	238	6312ZZ	6212ZZ	48 k6	110	14	9	5.5	161			
													242	6312ZZ	6209ZZ
													238	6312ZZ	6212ZZ
20	5	19	45	238	6312ZZ	6212ZZ	55 m6	110	16	10	6	182			
													6312ZZ	6212ZZ	
20	5	19	63	267	6313ZZ	6212ZZ	55 m6	110	16	10	6	282			
													6313ZZ	6212ZZ	
22	5	19	63	293	6314C3	6312C3	55 m6	110	16	10	6	345			
													6314ZZ	6312ZZ	
22	5	19	91	332	6313C3	6313C3	55 m6	110	16	10	6	490			
													6316	6313ZZ	
22	5	19	91	332	6313C3	6313C3	55 m6	110	16	10	6	550			
													6316	6313ZZ	
25	6	24	91	358	6313C3	6313C3	55 m6	110	16	10	6	690			
													*NU318	6315ZZ	
25	6	24	91	358	6313C3	6313C3	55 m6	110	16	10	6	800			
													*NU318	6315ZZ	
25	6	24	91	358	6313C3	6313C3	55 m6	110	16	10	6	950			
													*NU318	6315ZZ	

주)
 1. 키 및 키 홈 공차 : KS B 1311
 2. * 는 BELT DRIVE OPTION BEARING을 나타내며 그 외는 BALL BEARING 임.
 3. FR.NO. 280L은 KS규격에 규정되어 있지 않는 FRAME SIZE임.(KS규격은 315FR.임)