

BALL JOINT(CONSTANT VELOCITY) *himco*⁸⁷

● DRUM Type

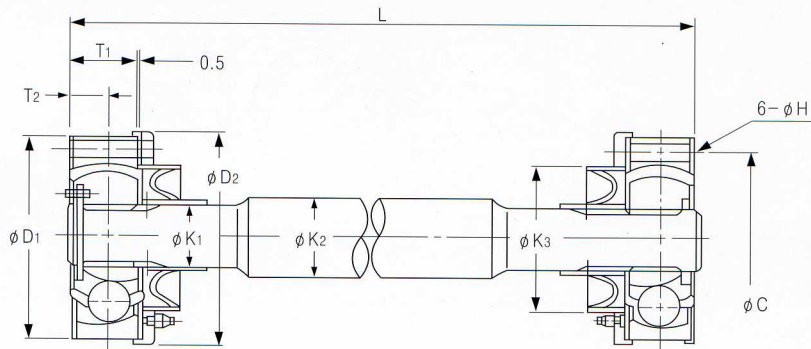

SIZE	記號 Mark	φ D1	φ D2	φ K1	φ K2	φ K3	φ C	φ H	φ T1	φ T2	L	Max. Angle	Torque (kgf.m)
BJ 75		80	85	22.33	25	51	66	9	24.4	12.2	220	14 °	60
BJ 95		95	100	26.36	30	64	80	9	32.0	16.0	250	14 °	115
BJ 125		125	130	36.33	40	82	106	11	40.6	20.3	280	16 °	280
BJ 150		146	151	45.60	50	102	124	13	48.0	24.0	295	16 °	480
BJ 175		165	170	51.60	55	112	140	15	51.0	25.5	340	16 °	765
BJ 200		190	196	59.50	65	130	159	14	60.0	30.0	360	16 °	1140
BJ 225		212	218	65.40	70	152	180	14	65.0	32.5	400	16 °	1500
BJ 250		230	238	74.25	80	162	197	18	75.0	37.5	450	18 °	2110
BJ 300		266	273	83.40	90	186	225	18	84.0	42.0	500	18 °	2970

● Flange Type

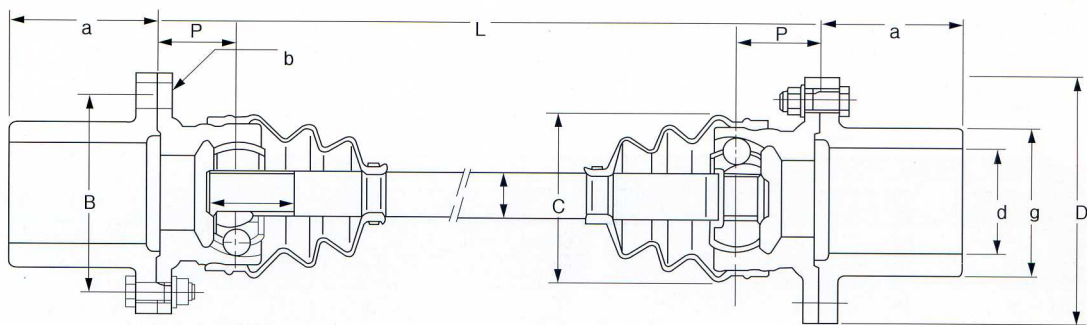

SIZE	記號 Mark	외륜 외경 C O.D. of Tire	Flange					P	전장(L) Total Length Min.	Torque (kgf.m)	각도 Angle (°)	
			D	g	Max. d	a	B					b
BJC 75		81	118	70	45	75	97	3-10.2	40	240	60	25 °
BJC 95		108	136	80	50	80	110	3-12.2	46	290	115	25 °
BJC 100		112	154	90	60	95	125	3-14.3	47	305	145	25 °
BJC 125		148	179	110	70	112	150	3-14.3	55	375	280	25 °
BJC 150		165	192	125	80	120	165	6-14.3	76	448	480	25 °
BJC 175		172	215	140	90	135	185	6-17	83	470	765	25 °
BJC 200		199	250	160	100	150	215	6-19	95	540	1140	25 °
BJC 225		222	265	175	110	165	228	6-21	105	580	1500	25 °